

Single Waler System

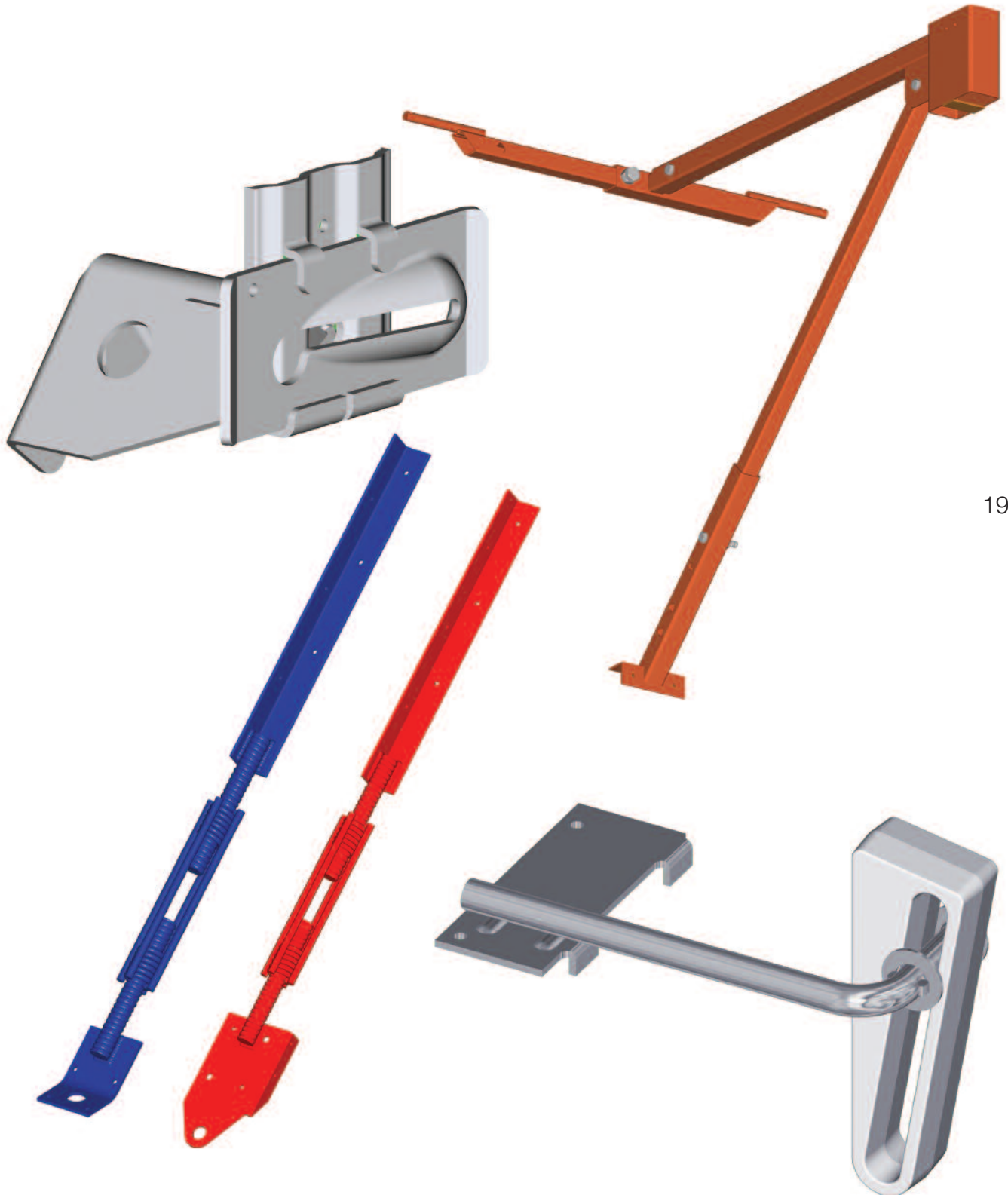

19 - 26

19

Single Waler System

SINGLE WALER SYSTEM

The Meadow Burke Single Waler System is an economical, modern wall forming method designed for use on straight, battered, curved and rounded walls and with various beam forms.

Whether your forming needs are for a four-foot knee wall or a twelve-foot retaining wall, the Single Waler System can accommodate all of your hand-set light forming requirements.

The complete System includes:

- Plastic cone or loose metal washer snapties with 4-3/4" ends
- Single Waler Bracket
- Form Aligner Clamp for strongbacks
- Snap Jack for walls over 8' high
- Form Aligner



20 See Page 25 for typical installation sequence.

(1025) ST-10 SNAP BRACKET

The ST-10 Snap Bracket is the key element of the Single Waler System. It is fabricated from heavy gauge steel and cadmium-plated for high corrosion resistance. This versatile bracket can be installed horizontally, vertically or even inverted with a 2x4 kicker plate. The Snap Bracket uses 4-3/4" L&W snapties and its sliding wedge has a 5/8" adjustment range for minor lumber variation.

The brackets can be installed before or after the wales have been placed and have a unique waler alignment feature not available on other brackets. Nailing the bracket and/or wedge to the wales is not required, but nail holes are provided and strategically placed, if needed.

To Order, Specify: quantity and type.

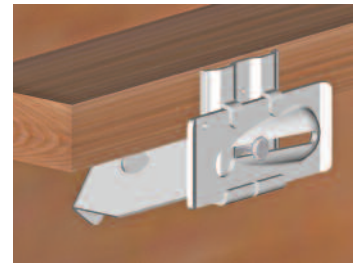
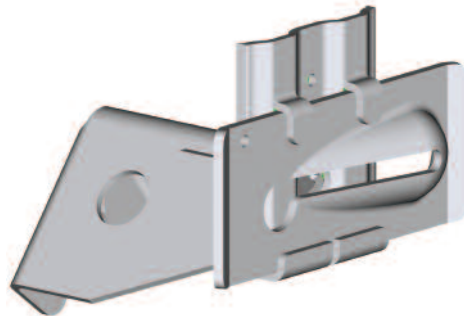

(1026) ST-11 FORM ALIGNER CLAMP

The ST-11 Form Aligner Clamp provides the Single Waler System with a fast and easy way to attach 2x4 strongbacks to the form. The galvanized clamp can be installed vertically or horizontally at any point on the form.

To Order, Specify: quantity and type.





ST-12

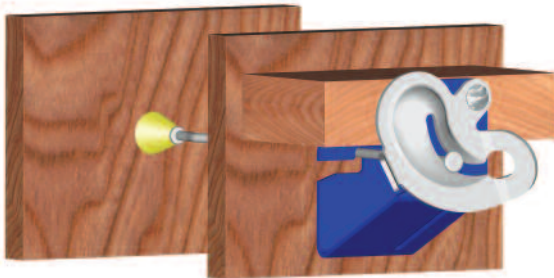

ST-13

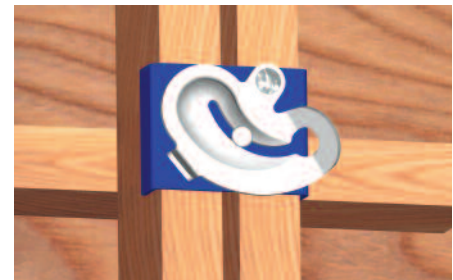

- (1027) ST-12 "A" Bracket
- (1028) ST-13 "C" Bracket

The ST-12 (Jahn) "A" Brackets by Meadow Burke are made of high strength steel with a cadmium plated eccentric and a rust-resistant painted body. Designed for use with a single 2x4 waler, the bracket is used to hold either a single horizontal wale, or a single vertical stud. The bracket can be installed either before or after walers are in place. Slots in the bracket allow it to slip over the snap tie end. Loading from the bracket is against the 2x4 instead of the plywood. The "A" bracket uses 4-3/4" L&W snap ties. Bracket will not loosen from internal vibration of the concrete.

The ST-13 (Jahn) "C" Bracket by Meadow Burke is used to attach single 2x4 studs and double vertical strong-backs for formwork alignment. Also engineered for use with double wales to support a horizontal plywood joint. Uses 8-1/4" L&W snap ties.

To Order, Specify: Quantity and type.

WALER SPACING AND TIE ALIGNMENT

Misalignment of walers can cause Snapties to bend. Bent Snapties will not carry the expected design loads and a premature failure may result.

Wales must be continuous with joints staggered. Do not omit any walers. Omitting one of a double waler set will cause load redistribution and can result in a tie failure. All wales must be in place and all ties must be positioned properly.

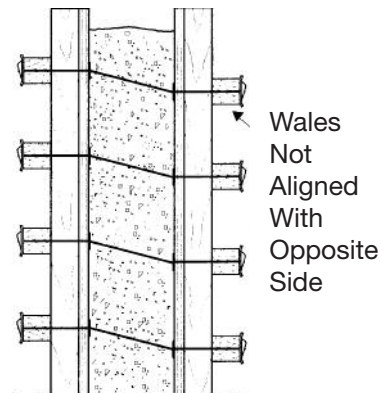

Single Waler System

(1029) ST-14 SNAP JACK

The ST-14 Snap Jack is an integral part of the Single Waler System and is used when forming walls over 8' high to support a work platform. The steel one-piece unit quickly attaches to a Single Waler Bracket. Reference the installation sequence below. The Snap Jack has a built-in guardrail adapter to accept 2x4 guardrails. The lower support angle is provided with nail holes in order to nail the jack to the waler for added safety. This ST-14 Snap Jack works with both ST-10 Single Waler Bracket and ST-12 "A" Bracket.

Safe working load is 800 lbs. based on an approximate 4:1 safety factor. Do not, under any circumstances, place the Scaffold Jacks more than 8' apart. Consult a Meadow Burke Service Center with questions concerning special load design applications.

To Order, Specify: quantity and type.

SNAP JACK INSTALLATION

- 22
- 1) The Snap Jack must be installed between and into two (2) Single Waler Brackets.
 - 2) Insert one end of the Snap Jack bar into one of the Single Waler Brackets. Slide the bar through the bracket until the opposite end of the bar clears the second bracket.
 - 3) Next slide the Snap Jack bar into and through the second bracket. Make sure that the bar extends past each of the brackets at least two (2) inches. Center the Snap Jack between the two brackets and nail the lower support angle to the wale.

(1031) ST-27 FORM ALIGNER

(1032) ST-28 FORM ALIGNER

The ST-27 & ST-28 Form Aligner are designed to align vertical formwork. The ST-27 Standard brace consists of a length of angle iron, a self-cleaning turnbuckle and a steel toe plate. The angle iron is equipped with nail holes allowing the Form Aligner to be attached to a 2x4 or 2x6 to extend the reach of the ST-27. The turnbuckle is fabricated with coil threads for quick and easy adjustments and the steel toe plate can accept a round steel stake, be nailed to a wood stake or be inverted and nailed directly to a stud or wales. The ST-28 Form Aligner is equipped with a spade-type toe plate designed for use with modular forms and wedge bolts.

The safe working load for the Form Aligner is determined by the method of attachment and the extension lumber used.

To Order, Specify: quantity and type.

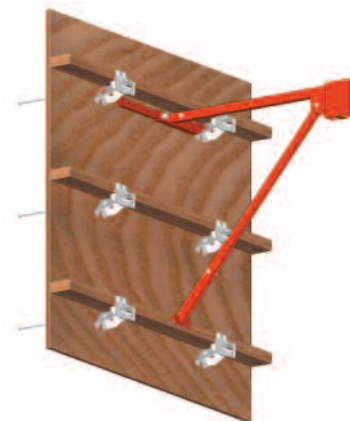
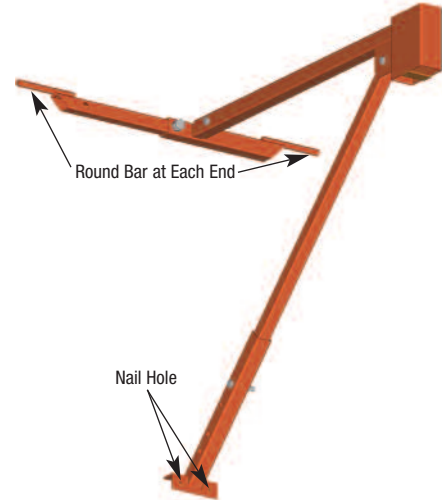

ST-27

ST-28

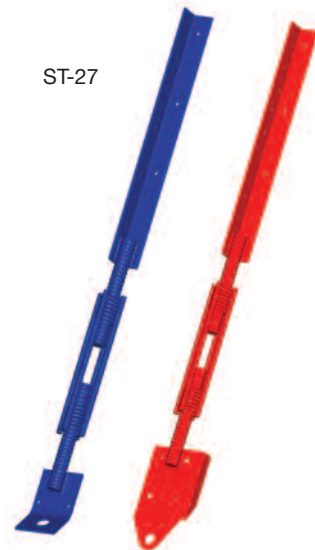

SINGLE WALER FORMING APPLICATION

Gang Drilling Plywood

Gang drilling is a quick and economical way to prepare plywood for the single waler forming application. Simply stack the plywood and drill the tie holes with a 5/8" drill bit. The System works equally well with 5/8" or 3/4" plywood. The wedge take-up in the bracket will compensate for the difference in plywood thickness.

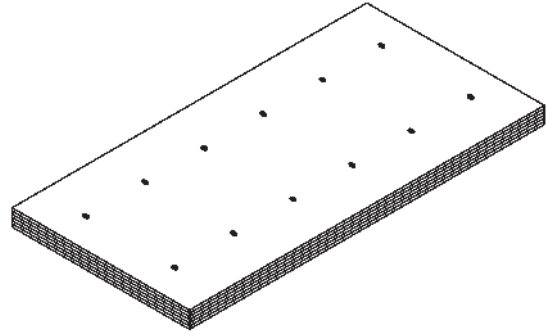

SINGLE WALER FORMING APPLICATION

Common Spacing Layouts

Maximum allowed form pressure is 4'-0" per hour at 70° F. Recommended 9/16" drill bit for form hole. Plywood thickness for this diagram is 3/4". Standard waler spacing is 16".

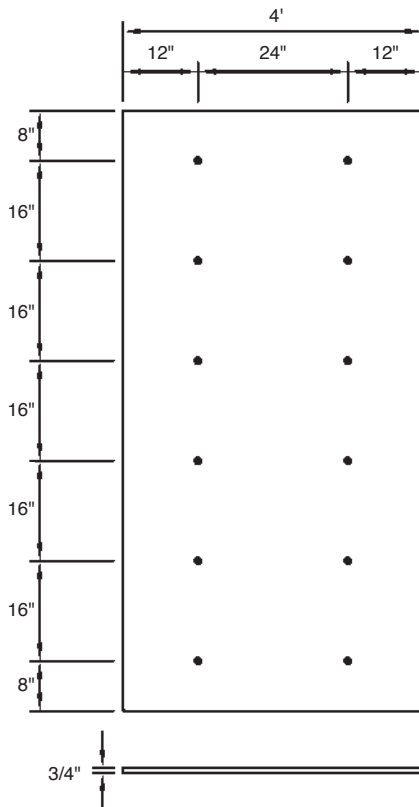

12 Holes

You can minimize the amount of ties required with this standard spacing layout. You can also eliminate the need of a starter plate on 8' walls.

Note: For $l/360$ deflection, use 12" waler spacing.

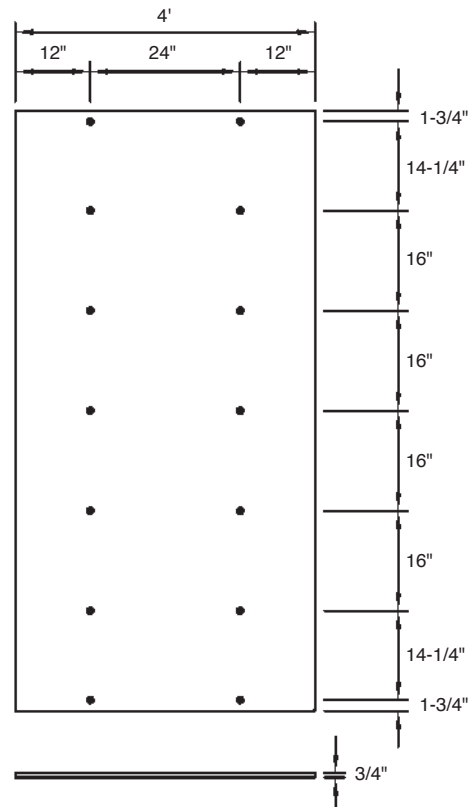

14 Holes

This pattern is required for walls over 8' or when panels are to be attached to a kicker plate with inverted brackets. With this panel layout, the top waler is used to start the next tier of panels.

Single Waler System

SINGLE WALER BRACKET INSTALLATION

Wall Height Considerations

Snaptie spacing is dependent upon form pressure and the type of forming used. Below are a few typical wall form spacing diagrams for various wall heights with pertinent notes for each height.

Wall Form 4 ft. High

- Install 4'x8' plywood horizontally. Attach 2x4 walers with horizontal tie-spacing of 2'-0" on center.

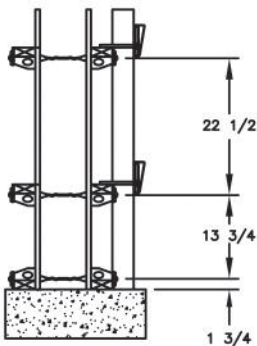

Wall Form 8 ft. High

- Attach strongbacks vertically to full height of form.
- Use proper spacing to engage next row of ties, while attaching waler with form aligner clamps.
- Easily attach plywood and secure with wrench head snapties and single waler forming brackets.

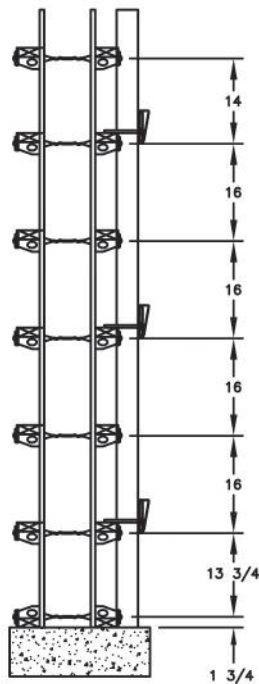

Wall Form Over 8ft. High

- Single or Double 2x4 strongbacks with support clamps fastened to every other waler provides a stable alignment for walls over 10 ft.
- Nail a waler to top of last waler at plywood joint.
- Nail aligner brace to vertical strongback at 1/3 height from top of form.
- Only one side needed for bracing.
- Form aligner brace spacing at 6 ft. on center.

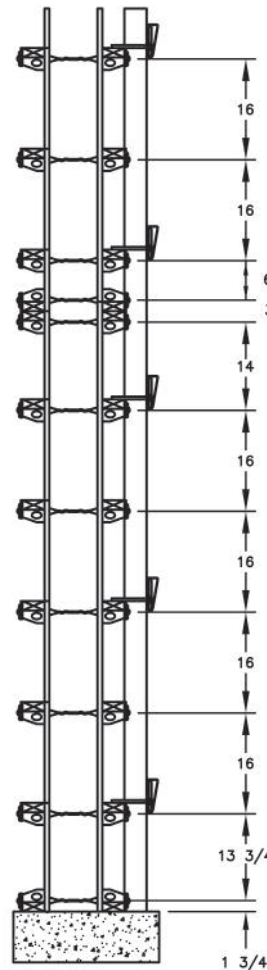

SINGLE WALER BRACKET INSTALLATION Typical Installation Sequence



1: Stack standard 3/4" or 5/8" plywood sheets. Drill with 9/16" drill bit.

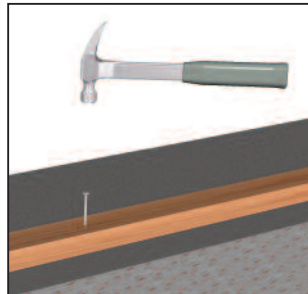

2: Nail 2x4 kicker plates to concrete footing with concrete nails.

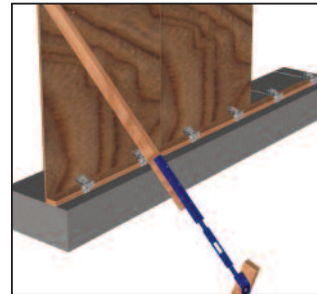

3: Nail vertical plywood panels to 2x4 kicker plate. (Or attached to inverted single waler brackets on kicker plate - support panels temporarily, as needed.)

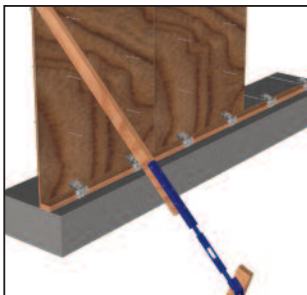

4: Place Snapties through pre-drilled panels from inside of form.

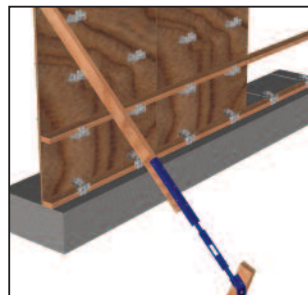

5: Attach Single Waler Brackets on snapties. Do not need to tighten an entire row before installing 2x4 waler. Repeat process for following rows.



6: Tap Single Walers with hammer to tighten. Place 2x4 strongbacks (if desired) and secure with Form Aligner Clamps.

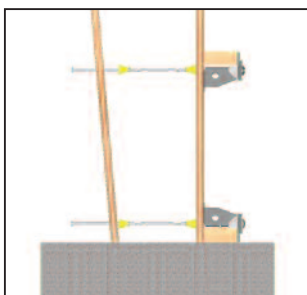

7: Install panels over snapties on opposite side and repeat steps 5 and 6 .

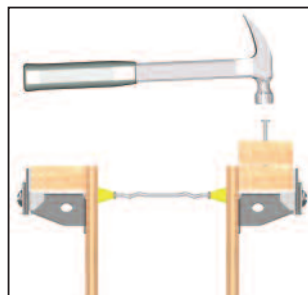

8: (OPTIONAL) For wall over 8 ft. high. Nail a 2x4 on top of last waler to act as kicker plate.

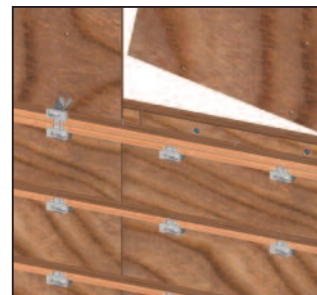

9: Following step 8, align above plywood panels against new top kicker plate and repeat steps 3 through 7. (Scaffolding required) See Snap Jack instructions.

Single Waler System

(1058) ST-32 MASONRY BEAM CLAMP – Standard

The ST-32 Standard Beam Clamp is used for forming poured concrete lintels with Masonry block walls. Meadow Burke ST-32 Standard Beam Clamp fits over 5/8" or 1/4" plywood form and is manufactured to form lintel beam over openings in an 8" block wall or 12" block wall. Meadow Burke design provides for a double 2x4 aligner beam. Made from 1-1/4" x 1-1/4" x 1/8" steel angle.

ST-32 MASONRY BEAM CLAMP		
Number	Wall Thickness	Plywood Thickness
1	8"	5/8"
2	8"	3/4"
3	12"	5/8"
4	12"	3/4"

To Order, Specify quantity, type and number.

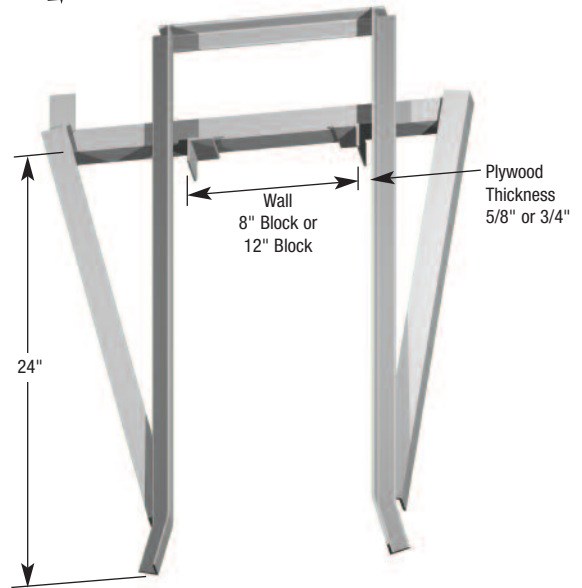
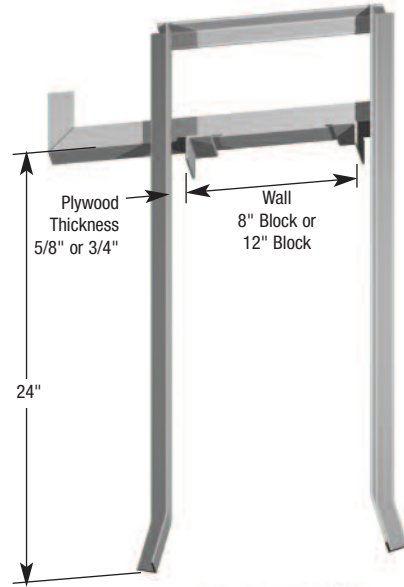

(1059) ST-33 MASONRY BEAM CLAMP – Heavy with Brace

The ST-33 Heavy Beam Clamp is designed for same forming as ST-32, but is stronger due to addition of external braces to limit deflection. Also designed to fit over 5/8" or 3/4" plywood form and is manufactured to form lintel beam over 8" block wall or 12" block wall. Meadow Burke design provides for a double 2x4 aligner beam. Made from 1-1/4" x 1-1/4" x 1/8" steel angle.

ST-33 MASONRY BEAM CLAMP		
Number	Wall Thickness	Plywood Thickness
1	8"	5/8"
2	8"	3/4"
3	8"	7/8"
4	12"	5/8"
5	12"	3/4"
6	12"	7/8"

To Order, Specify quantity, type and number.

